

BRASS CHECK VALVE TYPE EUROPA® A.C.S.



ISO 9001 : 2015



Size : DN 3/8" to 4"
Ends : Female BSP
Min Temperature : - 10°C
Max Temperature : + 100°C
Max Pressure : 25 Bars up to DN 1"
Specifications : All positions
Female / Female BSP
Brass / S.S. throttle

Materials : Brass body CW617N

BRASS CHECK VALVE TYPE EUROPA® A.C.S.

SPECIFICATIONS :

- Respect the flow direction indicated by the arrow
- All positions with SS 302 spring
- Female / female type
- Brass / S.S. throttle
- Weak head loss thanks to the cylindrical internal designing
- Low pressure opening
- Double axial and lateral guide for a better centering of the throttle on the seat
- Brass CW617N body for a better mechanical strength
- NBR gasket for a better tightness for high and low pressure

USE :

- Heating, drinking water, compressed air, domestic fuel oil
- Min Temperature Ts : - 10°C
- Max Temperature Ts :+ 100°C
- Max Pressure Ps : 25 bars up to DN 1" , 18 bars from DN 1 1/4 to DN 2" and 12 bars over
- Vacuum : between 300 and 500 mbar (from 50 to 70%)

BRASS CHECK VALVE TYPE EUROPA® A.C.S.

HEAD LOSS GRAPH :

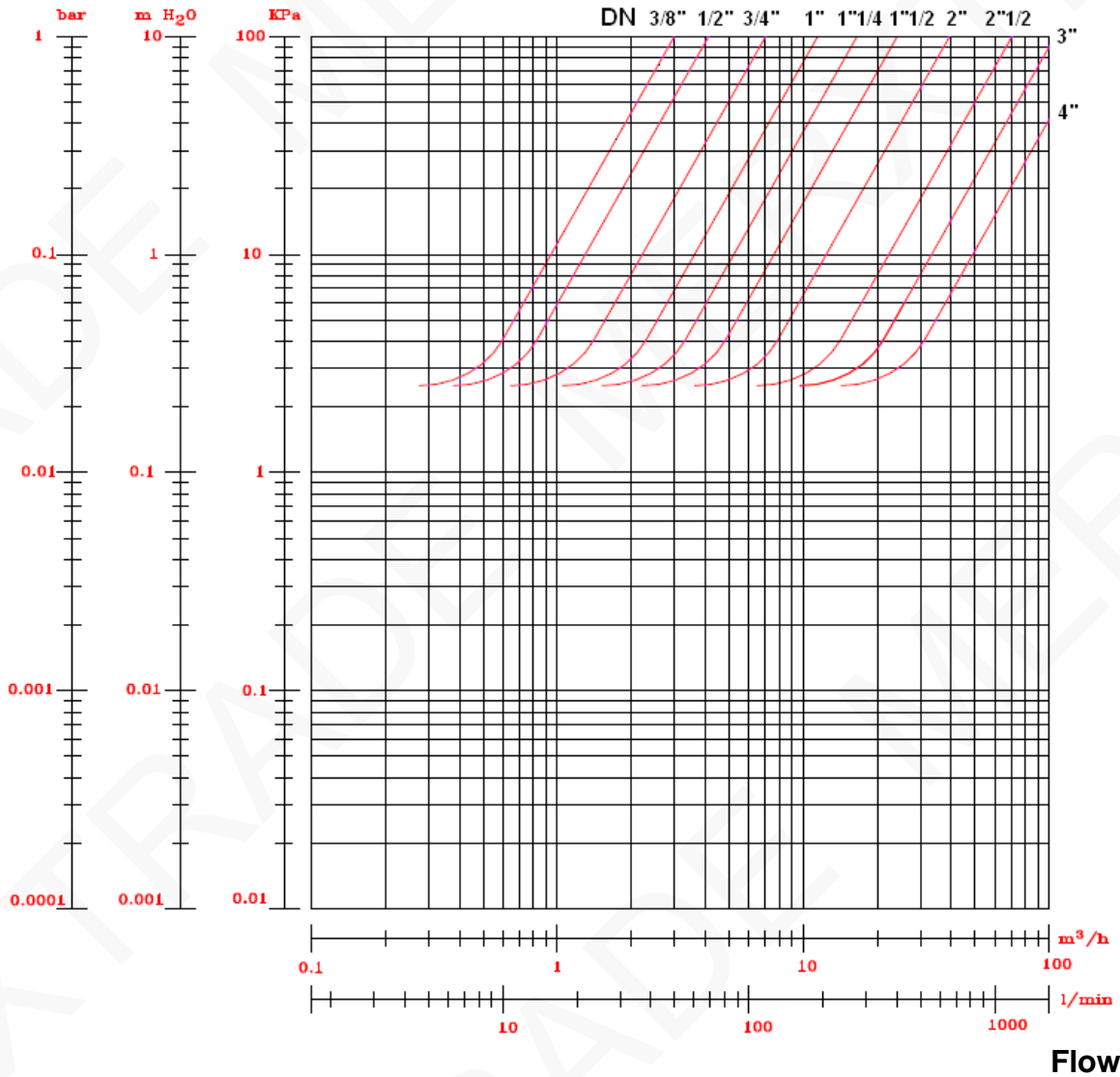

FLOW COEFFICIENT Kvs (m3 / h) :

DN	3/8"	1/2"	3/4"	1"	1 1/4"	1 1/2"	2"	2 1/2"	3"	4"
Kvs (m3 / h)	2.99	4.12	7.03	11.45	16.54	24.12	39.32	70.64	105.60	155.30

OPENING PRESSURE :

- Opening pressure between 20 and 200 mbar

RANGE :

- Threaded BSP cylindric female from DN 3/8" to DN 4"

BRASS CHECK VALVE TYPE EUROPA® A.C.S.

MATERIALS :

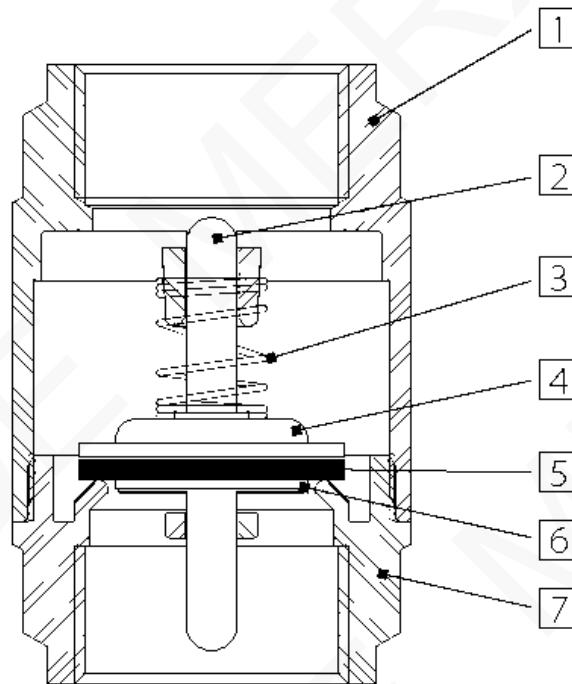

Item	Designation	Materials
1	Body	Brass CW 617 N according to EN 12165
2	Stem	Brass CW 614N according to EN 12164
3	Spring	SS 302
4	Ring	SS 304
5	Gasket	NBR
6	Throttle	Brass CW 614N according to EN 12164
7	Bonnet	Brass CW 617 N according to EN 12165

BRASS CHECK VALVE TYPE EUROPA® A.C.S.

SIZE (in mm) :

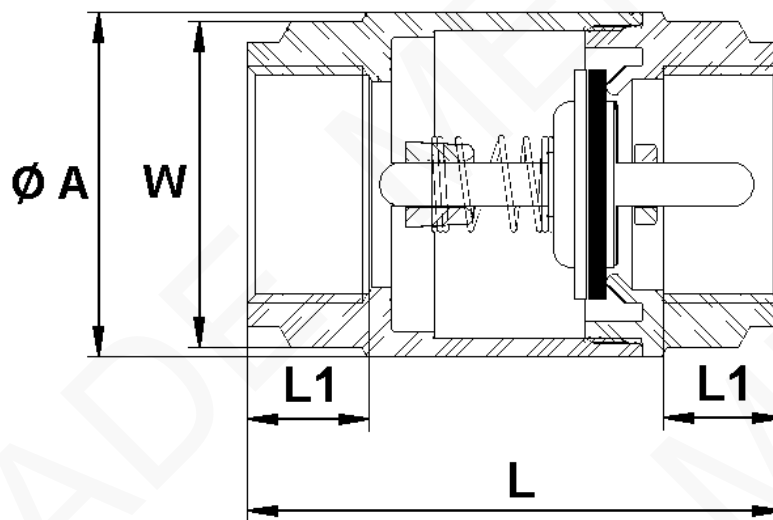

Ref.	DN	3/8"	1/2"	3/4"	1"	1"1/4	1"1/2	2"	2"1/2	3"	4"
305	L	55	58.5	65	74.5	83	93	101	122	141.5	158.5
	L1	11	13	14	17	18	19	21	26	27	28
	Ø A	34.5	34.5	41.5	48	60.5	71	87	120	140.5	172.5
	W (on flat)	23	27	33	40	50	55	70	87	102	128
	Weight (Kg)	0.187	0.195	0.278	0.407	0.643	0.871	1.307	2.935	4.251	6.542

BRASS CHECK VALVE TYPE EUROPA® A.C.S.**STANDARDS :**

- Fabrication according to ISO 9001 : 2015
- DIRECTIVE 2014/68/EU : Products excluded from directive (Article 4, § 3)
- French water agreement **A.C.S. N° 18 ACC NY 088**
- Threaded female BSP cylindrical ends according to ISO 228-1

ADVICE : Our opinion and our advice are not guaranteed and MXT shall not be liable for the consequences of damages. The customer must check the right choice of the products with the real service conditions.

BRASS CHECK VALVE TYPE EUROPA® A.C.S.

INSTALLATION INSTRUCTIONS

GENERAL GUIDELINES :

- Ensure that the check valves to be used are appropriate for the conditions of the installation (type of fluid, pressure and temperature).
- Be sure to have enough valves to be able to isolate the sections of piping as well as the appropriate equipment for maintenance and repair.
- Ensure that the valves to be installed are of correct strength to be able to support the capacity of their usage.

INSTALLATION INSTRUCTIONS :

- **Before installing the check valves, clean and remove any objects from the pipes** (in particular bits of sealing and metal) which could obstruct and block the valves.
- **Ensure that both connecting pipes either side of the check valve (upstream and downstream) are aligned** (if they're not, the valves may not work correctly).
- **Make sure that the two sections of the pipe (upstream and downstream) match, the check valve unit will not absorb any gaps. Any distortions in the pipes may affect the tightness of the connection, the working of the check valve and can even cause a rupture.** To be sure, place the kit in position to ensure the assembling will work.
- Before starting the fitting, ensure that the threads and tapping are clean.
- **If sections of piping do not have their final support in place, they should be temporarily fixed. This is to avoid unnecessary strain on the check valve.**
- The theoretical lengths given by ISO/R7 for the tapping are typically longer than required, the length of the thread should be limited, and **check that the end of the tube does not press right up to the head of the thread.**
- For the sealing assembly check valve piping, it is essential to use products that are compatible with the requirements of the French water agreement ACS : **plumbers hemp proscribed.**
- If mounting on an air conditioning with PER tubing and hoses, it is necessary to support the tubes and hoses with the fixing to avoid strain on the check valve.
- When screwing the check valve, ensure that you only rotate on screwed side by the 6 ended side. Use an open ended spanner or an adjustable spanner and not a monkey wrench.
- **Never use a vice to tighten the fixings of the check valve.**
- Do not over tighten the check valve. Do not block with any extensions as it may cause a rupture or weakening of the casing.
- **In general, for all check valves used in buildings and heating, do not tighten above a torque of 30 Nm.**
- If there is a direction changing or if there's another material, it's better to take away the check valve so that it is outside the turbulence area (**between 3 and 5 times the ND before and after**).
After a pump please refer to norm NF CR 13932 to install the check valve.